



型號：RDC-1000L

對照型
Separate
Type



Detecting Distance	10M
Standard Object	Opaque 16mm
Hysteresis	±15%
Indicator	RED LED
Sensitivity	adjustable
Operating Temperature	- 25°C to + 55°C
Operating Humidity	35 to 85% RH
Ambient Operating Illumination	10000 Lux
Power Supply	AC 20-260V DC 12-260V
Output	1A1B
Current Consumption	2Va Max
Contact Current	30V DC 3A / 250V AC 3A
Residual Output Voltage	30 ms Max
Response Frequency	1.5ms Max
Vibration Resistance	10 55Hz : 1.5mm X,Y,Z Sustain 2 Hours
Shock Resistance	500m/S(約50g)X,Y,Z Sustain 3 Times
Protection	IEC ,IP 66
Cable Material	Length ; 2M Dia : 5mm 0.23m/5 inner cable
Housing Material	ABS
Wire Material	PVC PVC Oil resistance
Weight	155g

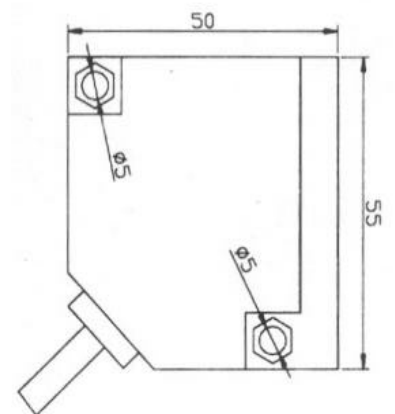
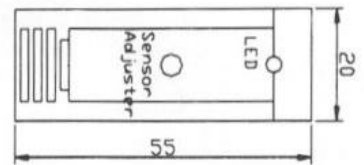

RE CHENG HSU AUTOMATIC INDUSTRIAL CO.,LTD

Address:NO.10.Lane 271,sec. 2 Pingdong Road.,
Pingjhen City,Taoyuan County 324,Taiwan(R.O.C)

TEL :886-3-460-1638

FAX :886-3-460-3820

E-mail : dsnfg02452@gmail.com

Website:<http://www.rc-drh.com.tw>

南區營業所:台南縣永康市中正北路54號5樓之13

TEL:06-2434092

FAX:06-2434093